



**POWER** LINX  
DUAL POWER HITCH

*Marcrest*  
Manufacturing Inc.

[www.marcrestmfg.com](http://www.marcrestmfg.com)



# POWER LINX

DUAL POWER HITCH

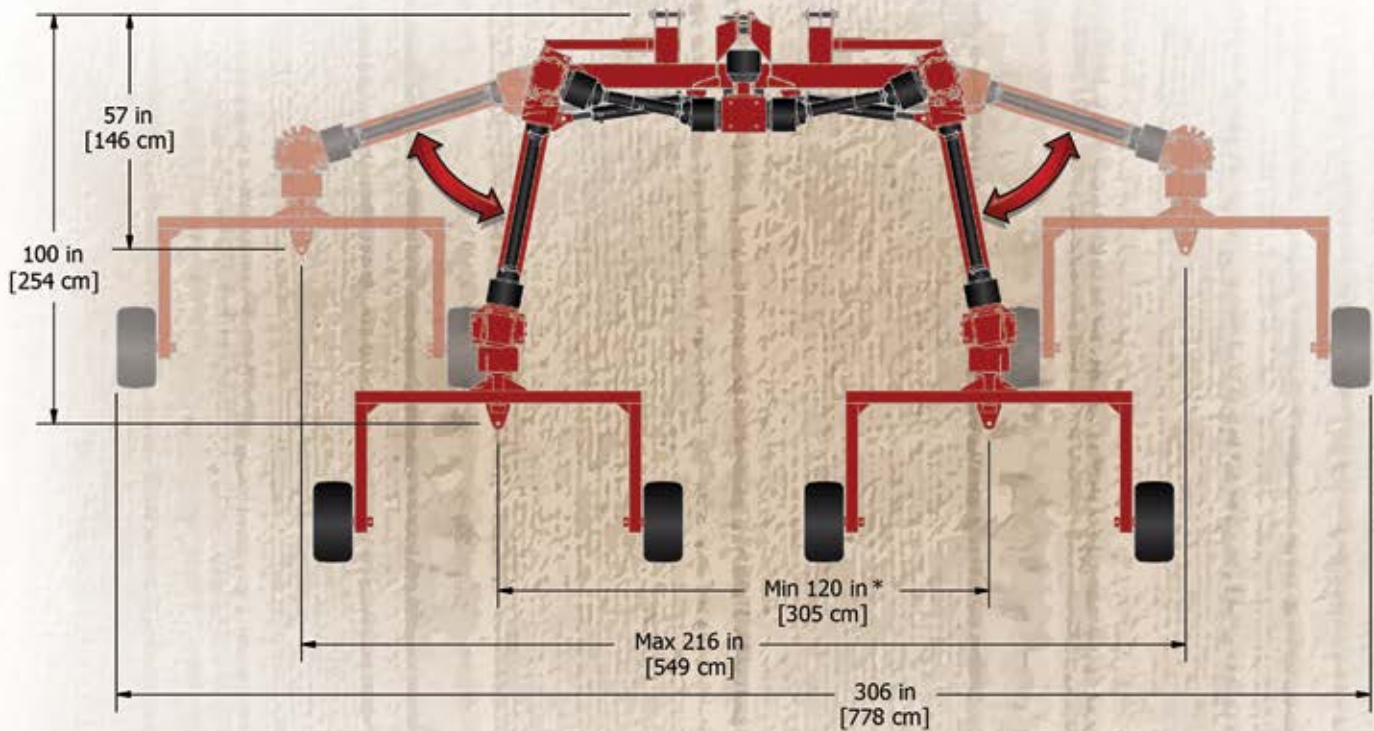

\* 120in (305cm) - 144in (366cm) Depending on Model of Baler

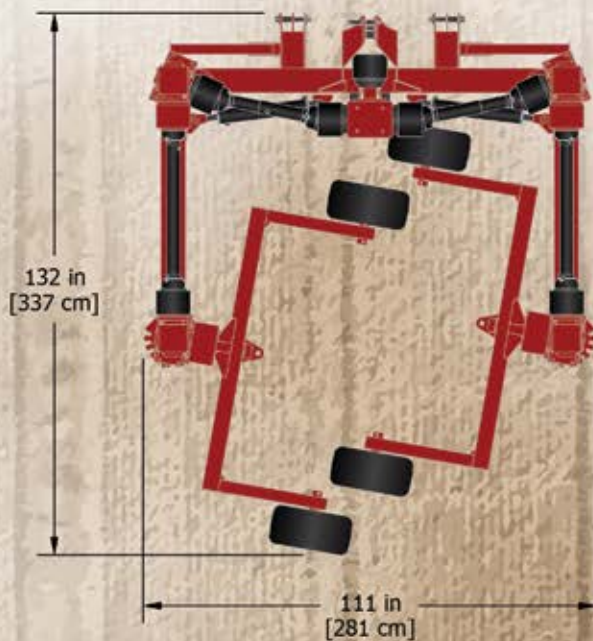

## Specifications

- Minimum Horse Power required 90 HP
- Horse Power Rating 150 HP
- Quick Hitch Compatible
- PTO (input) 1,000 RPM 1-3/8"-21
- PTO (output) 540 RPM 1-3/8"-13
- Hitch 3PH Cat. 2 and Cat. 3
- 2 Remotes Required





*Marcrest*  
Manufacturing Inc.

## Work Twice As Hard with Half the Labour and Tractors

### Do a Double Take

The Power Linx - Dual Power Hitch saves on labour and equipment cost. You can now bale twice as much with one less man and one less tractor. Power Linx takes the PTO power from one tractor (90-150 HP) and splits it in two. Your tractor now easily operates two balers at once getting you out of the field in half the time.

### Get Around

The short coupled compact design allows for short cornering for better maneuverability on headlands. Swivel gearboxes take the power to the balers and also allow sharp turning with no driveline chattering for long life and trouble free operation. The trailing dolly design follows the ground contour well, enabling the baler pickup to make a clean sweep, it also allows for sharp cornering keeping balers in line with the swaths.

### In-Field Adjustments at Hand

Both arms independently hydraulically swing and are controlled via tractor remotes. This gives you the power to adjust to varying field conditions to one or both arms while on the go.

### Simple Performance

One of the best parts of the Power Linx - Dual Power Hitch is that it will work with any baler. No modifications needed on the balers. Just pin up, attach PTO and go.

### Lift and Lock Feature

When you need to back up, lifting the 3PH will lock the dollies and keep them from turning. With this feature and independent hydraulic swing on the arms, this enables you to steer the balers while backing up.





# POWER LINX

DUAL POWER HITCH



## Other Products from Marcrest Manufacturing



**Bale Baron**



**The Claw**



**The Squeeze**



**The Pinch**

**Marcrest**  
Manufacturing Inc.

45010 Cardiff Road  
R.R. #1 Ethel, Ontario Canada, N0G 1T0

Phone: 1-519-887-9910

Fax: 1-519-887-9962

Email: [info@marcrestmfg.com](mailto:info@marcrestmfg.com)

[www.marcrestmfg.com](http://www.marcrestmfg.com)